

LEGEND:

- H141 LINE: ———
- H141 STR: 182

DWG REV	EPN/DESCRIPTION	CONT/PE#	DATE	DRN	CHKD	APPR
1	SUBMITTED TO PUC		05/21	GBS	CJN	JRS

EVERSOURCE ENERGY

H141, 115kV LINE
STATE OWNED LAND CROSSING, LOCATION PLAN
BRENTWOOD, NEW HAMPSHIRE
EXHIBIT 1

T	1
DRAWN GBS	
ENGINEER CJN	
CHECKED CJN	
APPROVED JRS	
DATE 05/07/21	

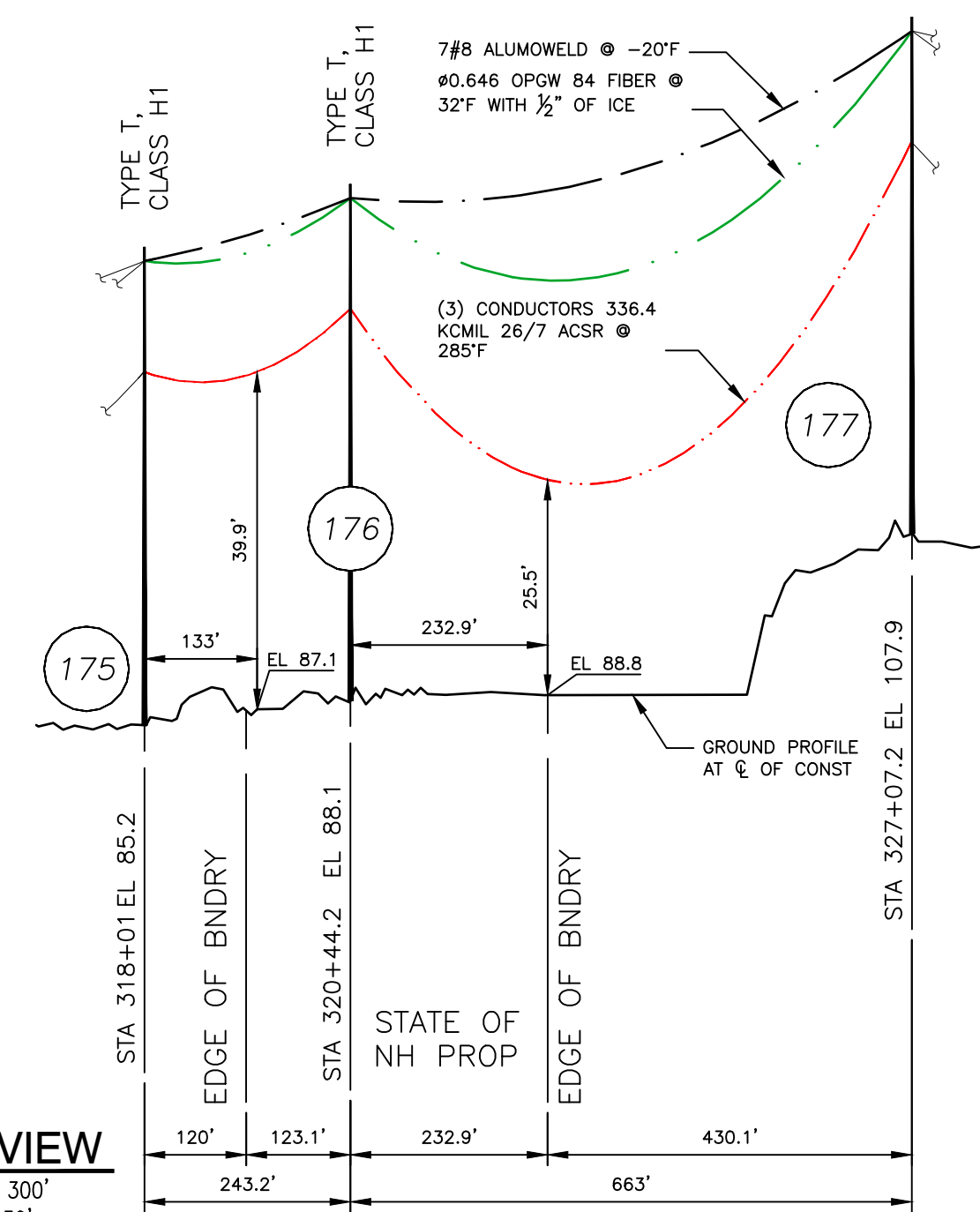
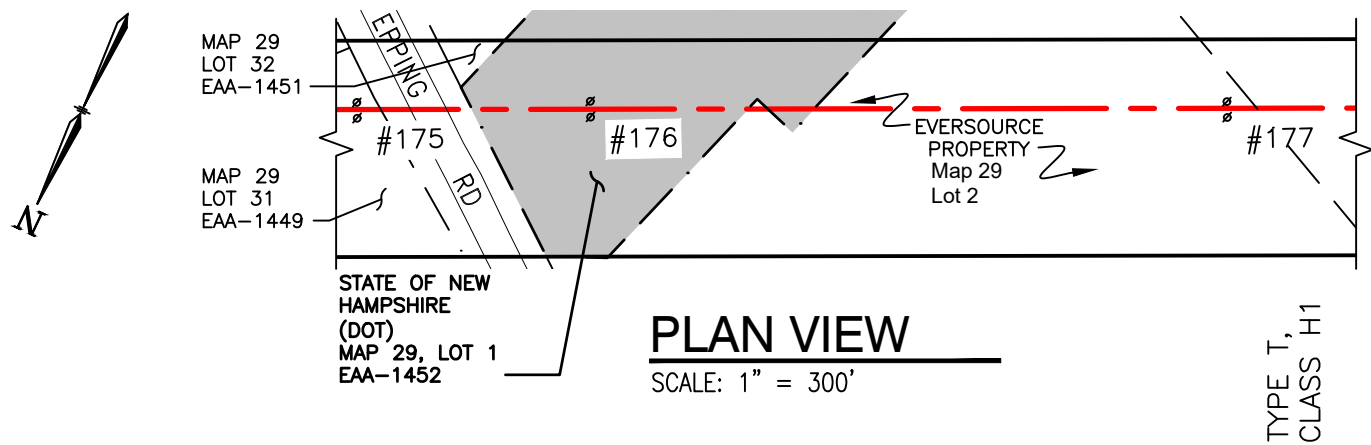

STRUCTURE LOCATION		
STRUCTURE	LONGITUDE	LATITUDE
175	-71.00125401	43.01067669
176	-71.00207593	43.01039159
177	-71.00432241	43.00962285

- LEGEND:**
- #177 STRUCTURE
 - STATE OF NEW HAMPSHIRE PROPERTY
 - PROP BOUNDARY
 - H141 LINE 115KV LINE, Q OF CONST
 - LIMITS OF EVERSOURCE RIGHT OF WAY

- NOTES:**
- PARCEL INFORMATION PROVIDED BY NH GRANIT.
 - ELEVATIONS REFERENCED TO THE NORTH AMERICAN VERTICAL DATUM OF 1988.

NESC VERTICAL CLEARANCE (FT) FROM TABLE 232.1	
NATURE OF SURFACE UNDERNEATH WIRES, CONDUCTORS OR CABLES	115kv
OTHER AREAS TRAVERSED BY VEHICLES SUCH AS CULTIVATED, GRAZING FOREST AND ORCHARDS LAND, INDUSTRIAL SITES, COMMERCIAL SITES ETC	20.1

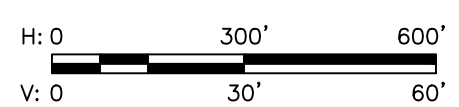

EVERSOURCE ENERGY

H141, 115kV LINE
STATE OWNED LAND CROSSING
EXETER, NEW HAMPSHIRE
EXHIBIT 2

T	1
DRAWN	GBS
ENGINEER	JRS
CHECKED	SDR
APPROVED	JRS
DATE	5/13/2020

DWG REV	EPN/DESCRIPTION	CONT/PE#	DATE	DRN	CHKD	APPR
1	SUBMITTED TO PUC		05/21	GBS	CJN	JRS

SCALE AS SHOWN
FILE: H14143501.DWG
DRAWING NO. H14143501

ES VER: 12/2016

5/26/2021 8:59 AM - sullivan - S:\Lines\Line 115kV\115 - H141\H14143501.dwg - EXHIBIT 3 (LAND CROSSING)

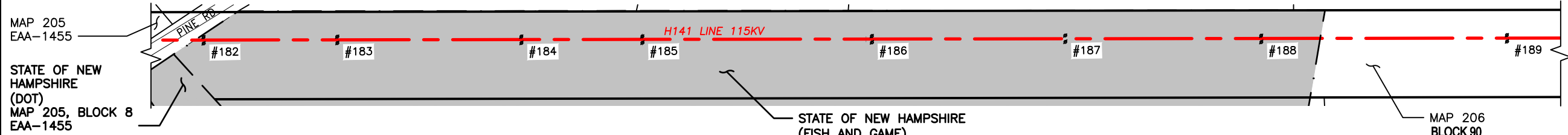

STATE OF NEW HAMPSHIRE (FISH AND GAME)
MAP 203, BLOCK 36
EAA-1456

PLAN VIEW

SCALE: 1" = 300'

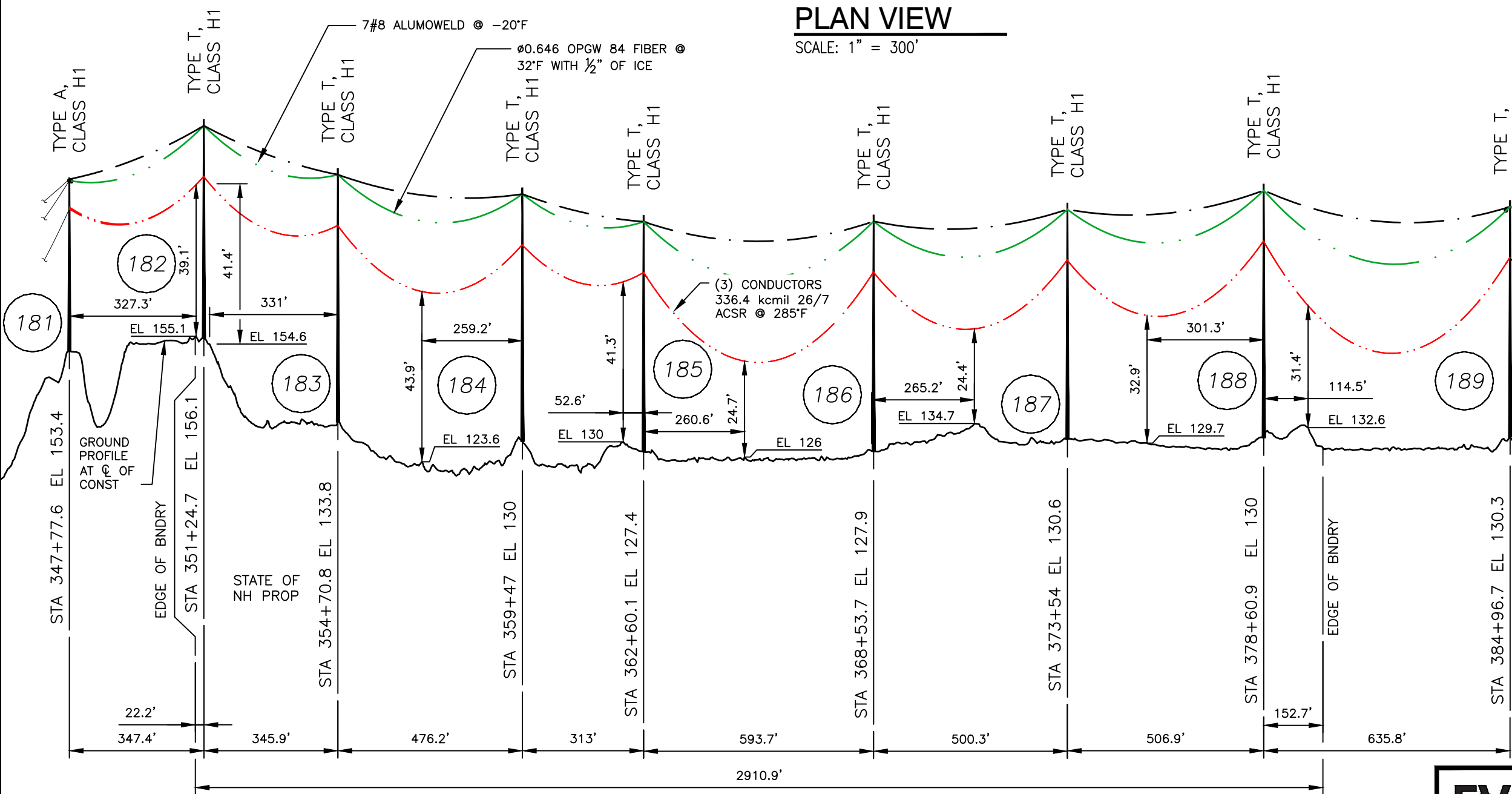

PROFILE VIEW

SCALE: HORZ 1" = 300'
VERT 1" = 30'

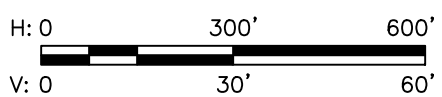

STRUCTURE LOCATION		
STRUCTURE	LONGITUDE	LATITUDE
181	-71.01132874	43.00720854
182	-71.01250592	43.00680606
183	-71.01367587	43.00640207
184	-71.01528866	43.00584887
185	-71.01634809	43.00548417
186	-71.01835763	43.00479278
187	-71.02004999	43.00420853
188	-71.02176776	43.00362161
189	-71.02391850	43.00287940

LEGEND:

- STRUCTURE
- #182
- STATE OF NEW HAMPSHIRE PROPERTY
- PROP BOUNDARY
- H141 LINE 115KV LINE, C_o OF CONST
- LIMITS OF EVERSOURCE RIGHT OF WAY

NOTES:

1. PARCEL INFORMATION PROVIDED BY NH GRANIT.
2. ELEVATIONS REFERENCED TO THE NORTH AMERICAN VERTICAL DATUM OF 1988.

NESC VERTICAL CLEARANCE (FT) FROM TABLE 232.1	
NATURE OF SURFACE UNDERNEATH WIRES, CONDUCTORS OR CABLES	115kv
OTHER AREAS TRAVERSED BY VEHICLES SUCH AS CULTIVATED, GRAZING FOREST AND ORCHARDS LAND, INDUSTRIAL SITES, COMMERCIAL SITES ETC	20.1

EVERSOURCE ENERGY

H141, 115kV LINE
STATE OWNED LAND CROSSING
BRENTWOOD, NEW HAMPSHIRE
EXHIBIT 3

T	1
DRAWN	GBS
ENGINEER	JRS
CHECKED	SDR
APPROVED	JRS
DATE	1/16/2020

DWG REV	EPN/DESCRIPTION	CONT/PE#	DATE	DRN	CHKD	APPR
1	SUBMITTED TO PUC		05/21	GBS	CJN	JRS

SCALE AS SHOWN
FILE: H14143501.DWG
DRAWING NO. H14143501

CABLE SCHEDULE						
WIRE	QTY OF CABLES	DESCRIPTION	DESIGN CONDITIONS			
			MAX DESIGN TENSION (lb)	TEMP (°F)	ICE (in)	WIND (psf)
CONDUCTOR	3	ACSR, 336.4 kcmil 26/7, LINNET	4000	0	0.5	4
STATIC	1	7 No. 8 AW	4200	0	0.5	4
OPGW	1	84F Ø0.646" OPGW	4500	0	0.5	4

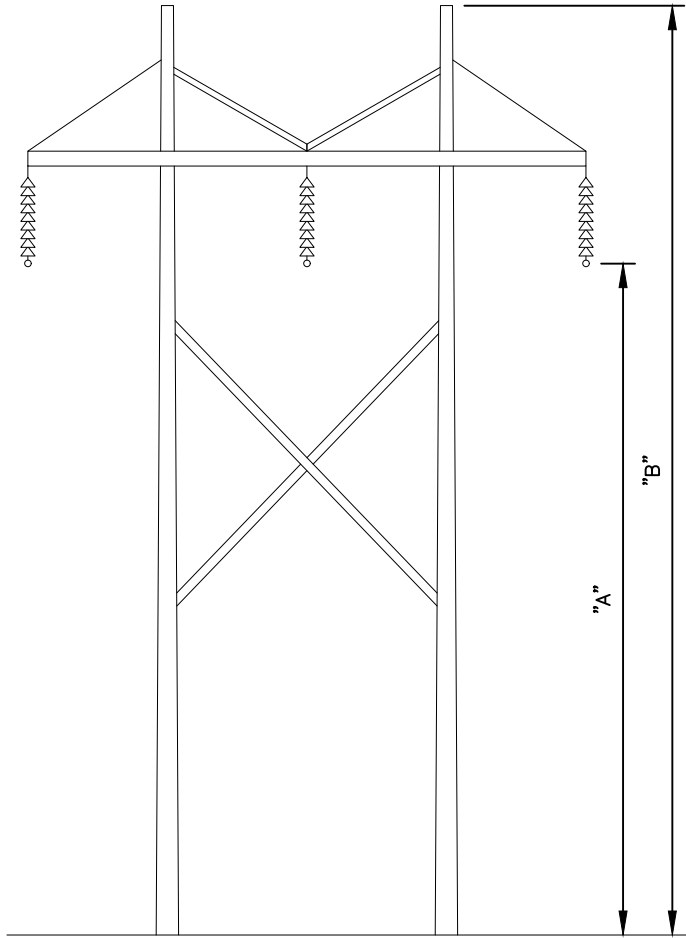

STRUCTURE DETAIL

SCALE: NTS

STRUCTURE DIMENSIONS		
STR	DIMENSION (ft)	
	"A"	"B"
175	41.8	56.5
176	46.3	61.0
177	46.3	61.0
181*	36.7	44.7
182	37.3	43.3
183	42.3	54.6
184	42.3	54.6
185	38.6	50.8
186	42.3	54.6
187	42.3	54.6
188	46.1	58.3
189	38.6	50.8

* STR 181 SEE NOTE 2

NOTES:

- EVERSOURCE TYPE T IS A SINGLE CIRCUIT STEEL TWO POLE H-FRAME TANGENT STRUCTURE WITH CROSS BRACING IN A HORIZONTAL CONFIGURATION.
- EVERSOURCE TYPE A IS A SINGLE CIRCUIT WOOD TWO POLE H-FRAME TANGENT STRUCTURE WITH CROSS BRACING IN A HORIZONTAL CONFIGURATION.

DWG REV	EPN/DESCRIPTION	CONT/PE#	DATE	DRN	CHKD	APPR
1	SUBMITTED TO PUC		05/21	GBS	CJN	JRS

<h1>EVERSOURCE ENERGY</h1> <p>H141, 115kV LINE STATE OWNED LAND CROSSING, STRUCTURE BRENTWOOD, NEW HAMPSHIRE EXHIBIT 4</p>	T	1
	DRAWN GBS	
	ENGINEER CJN	
	CHECKED CJN	
	APPROVED JRS	
	DATE 05/07/21	
SCALE NTS	FILE: H14143501.DWG IMAGE:	DRAWING NO. H14143501