

# Z180 Line Structure Replacement Project

Holderness and Campton, New Hampshire  
Environmental Resources Map

Date: January 06, 2023

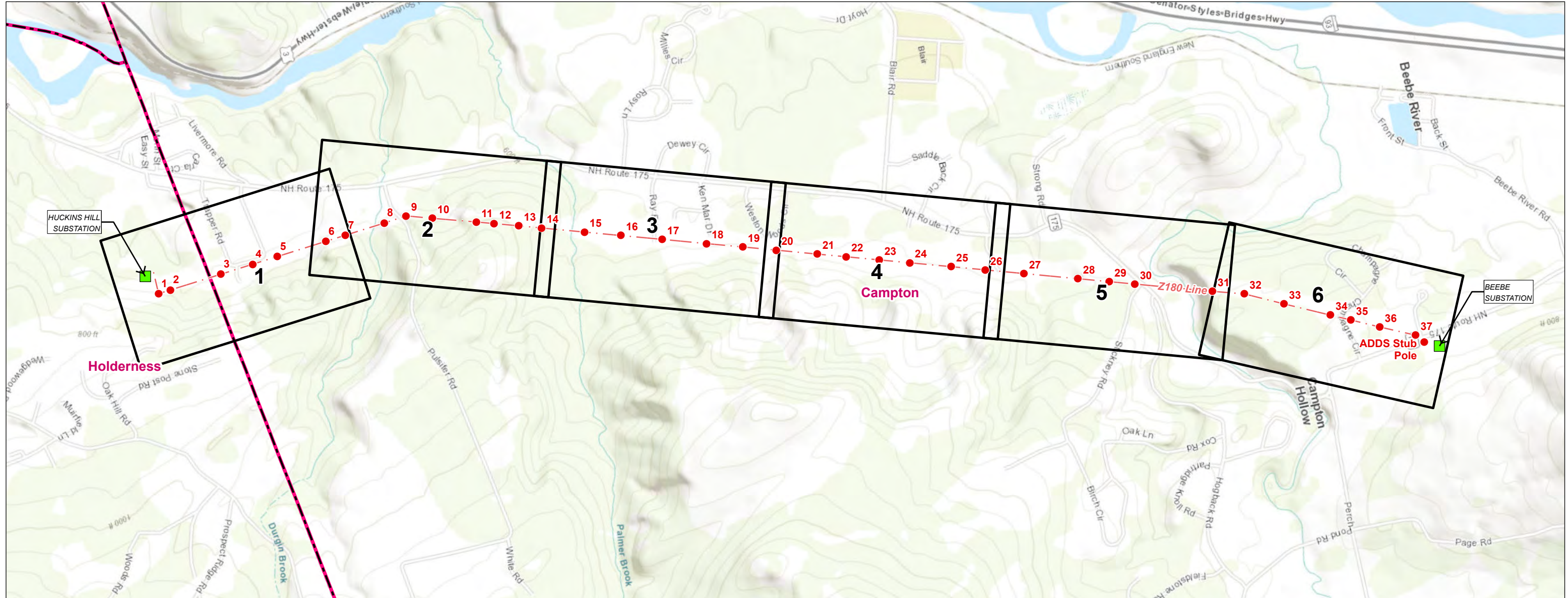

### Legend

- Substation
- Proposed Structure
- - - Overhead Eversource Line
- Map Sheet
- Municipal Boundary

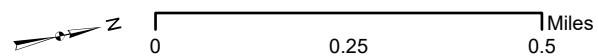

### INDEX OF FIGURES

Title Sheet / Index Map  
Map Sheets 1-6

NO.	DATE	REVISIONS

PREPARED FOR:



13 Legends Drive  
Hooksett, NH 03106

PREPARED BY:



2 Bedford Farms Drive Suite 200  
Bedford, NH 03110

# Construction Requirement Notes

Date Issued: January 6, 2023

## General Notes:

1. This plan set is intended to show the proposed replacement of the Z180 electric transmission line from the Huckins Hill Substation in Holderness, NH to the Beebe River Substation in Campton, NH.
2. Erosion control and temporary stormwater control measures shall comply with the New Hampshire Stormwater Manual Volume 3 – Erosion and Sediment Control During Construction December 2008 and the New Hampshire Department of Natural and Cultural Resources Best Management Practices Manual Utility Maintenance in and Adjacent to Wetlands and Waterbodies in New Hampshire, March 2019.
3. VHB Certified Wetlands Scientists reviewed and confirmed previously delineated wetlands performed by GZA along the PSNH Z180 ROW.
4. Wetland delineations were performed to the standards in the Corps of Engineers Wetland Delineation Manual and the Regional Supplement to the Corps of Engineers Wetland Delineation Manual: Northcentral and Northeast Region, Version 2.0 (January 2012).
5. Elevations are based contours derived from NH GRANIT LIDAR (Coastal New Hampshire 2015)
6. Proposed construction limits of disturbance are approximate. Contractor is responsible for minimizing earth disturbance, as practicable.
7. The environmental controls shown on these plans may need to be supplemented due to season of work or work methods proposed. Refer to BMP manuals and additional guidance documents, as needed.
8. Erosion and sedimentation control measures shall be installed prior to start of work, shall be maintained, and shall remain in place during construction until all disturbed surfaces are stabilized. Following stabilization, erosion and sedimentation control measures that are not compostable shall be removed and properly disposed of off-site.
9. Erosion and sedimentation controls shall be appropriate to the size and nature of the project and to the physical characteristics of the site, including slope, soil type, vegetative cover, and proximity to wetlands or surface waters. The type and installation method of erosion and sediment controls shall be in accordance with the BMP Manual for Utility Maintenance in and Adjacent to Wetlands and Waterbodies in New Hampshire ("BMP Manual") (NHDNCR, 2019).
10. Temporary stone construction entrances will be used at points of construction ingress/egress from public and private roadways.
11. The selected contractor is responsible for street sweeping at points of ingress/egress from public and private roadways.
12. Swamp matting shown on the plans represents the square footage and alignment of matting which is required and has been approved by the regulators. Additional layers of mats may be required at certain locations. Any increase in the number, change in alignment, or decision not to use swamp mats must be approved by the Permittee or an authorized representative of the Permittee(s) and, as appropriate, regulators.
13. Any excavated material shall be placed outside of jurisdictional areas or removed from the site.
14. If dewatering is required, dewatering basins shall be placed in uplands areas and discharge water into upland areas.
15. Areas of soil disturbance shall be stabilized following construction in accordance with the BMP Manual.
16. For work within the 100-year floodplain, there shall be no net additional fill placed, existing surface grades shall be restored upon completion of work.

## Construction Sequence

1. Prior to construction crew mobilization, wetland limits will be flagged with pink neon vinyl ribbons and vernal pool limits will be flagged with orange neon vinyl ribbons tied to vegetation and visible to the crews.
2. Proposed pole locations will be staked in the field with numbered grade stakes.
3. Crews will be provided with approved plans depicting work areas and required matting and erosion controls to be used to avoid and minimize jurisdictional impacts.
4. Civil crews will mobilize to the project vicinity. It is anticipated that the Contractor will secure a marshalling yard outside of the ROW in a previously disturbed or developed area that will be used for delivery of materials, field office and parking.
5. Crews will establish construction track pads, where appropriate, as access is established from public roads into the ROW. Traffic control will be implemented, as required, by DOT or local access approvals.
6. Erosion and sediment control BMPs will be installed prior to land disturbing activities.
7. Civil crews will begin removing topsoil and establishing gravel access roads along designated routes.
8. Timber matting will be laid down across wetland crossings and around existing pole locations that are in or adjacent to wetlands.
9. Once access is established, line crews will mobilize to start drilling activities associated with pole replacements and temporary poles.
10. New steel poles and temporary poles will be installed. Existing conductors and static wire will be transferred to new steel poles until all new steel poles are installed.
11. New conductor and optical grounding wire will replace existing conductor and static wire. Temporary poles will be removed.
12. Old poles, conductor, insulators, and any other type of construction debris will be removed from the site and properly disposed.
13. Work pad restoration will begin following line construction completion. Work pads will be covered with topsoil, seeded, and mulched. A portion of each work pad will be maintained for future access.
14. Timber matting will be removed from wetland areas. Care should be taken to remove any pieces of matting that break off during mat removal.
15. If required, wetland areas will be smoothed, seeded with an appropriate wetland seed mix, and mulched to ensure revegetation.
16. Access roads will be pulled back from wetland areas by a minimum of 10-15 feet.
17. Civil crews should ensure that appropriate water diversion BMPs implemented for the access roads are functioning prior to demobilizing from the ROW.
18. Sediment and erosion controls should remain in place until areas are stabilized and then be removed and properly disposed. If sediment and erosion controls can fully decompose, then erosion controls can remain in place after demobilization.
19. Wetland areas will be assessed by a qualified environmental monitor to ensure wetland vegetation is re-established within impacted areas prior to releasing the contractor.

### Invasive Species Control Plan

1. Workers who will be operating equipment in areas that may contain invasive plant species will be trained in the identification and modes of dispersal and spread of common, highly-prolific terrestrial invasive plant species that are commonly found within the utility ROW.
2. In locations where invasive infestations exist, the contractor shall minimize contact with invasive species by choosing access routes and staging areas that are outside areas of infestation to the greatest extent practicable.
3. The contractor will be responsible for certifying that all equipment on the project is clean of invasive species prior to arriving onsite. The contractor will also be responsible for cleaning equipment as it is moved within the project to reduce the risk of spreading invasive plant seeds and fragments.
4. Clean vehicles, equipment, materials, gear, footwear or clothing of all visible soil and plant material on site in the infested area, or as near as practical to the infested area, prior to leaving the project site.
5. Cleaning methods can include:
  - a. Use a brush, broom or hand tools to manually clean.
  - b. Clean debris off equipment such as construction matting by shaking or dropping mats in a controlled manner to dislodge attached soil and debris.
  - c. Compressed air.
  - d. Using low-or high-pressure wash stations provided containment is in compliance with wastewater discharge regulations.
6. Do not decontaminate equipment next to streams or water bodies that could potentially transport seeds or propagules.
7. Decontaminate equipment and materials that may be contaminated by aquatic plant materials adjacent to the surface water they were exposed to prior to use in another surface water body.
8. Do not transport water withdrawn from a surface water body and discharge it to another water body.
9. Stabilize disturbed soils as soon as possible by seeding and/or using mulch, straw or gravel that is free of invasive plant material.
10. Where possible, when excavating soils, top layers of soil containing plant material and roots should be segregated from sub soils and left on site.
11. Do not transport fill and material containing invasive plant material onto a project site.
12. If fill and materials containing invasive species must be transported off site, cover soil and other material containing invasive plant material during transport and do not reuse. Stockpile or dispose of these materials in such a manner that would not promote the spread of invasive plants.

### Erosion Control

1. The project shall be managed in a manner that meets the requirements and intent of RSA 430:53 and chapter AGR 3800 relative to invasive species.
2. Prior to starting any earth moving operations, the contractor shall notify appropriate agencies and shall install erosion control measures as shown on the plans, as field and as identified in federal, state, and local approval documents pertaining to this project and as field conditions dictate.
3. Temporary water diversion (swales, basins, etc.) must be used as necessary until areas are stabilized.
4. Diversion swales and other temporary BMP's shall be installed early on in the construction sequence (before rough grading).
5. Contractor shall inspect and maintain erosion control measures, and remove sediment therefrom on a weekly basis and within twelve hours after each storm event (0.5" of rainfall or greater) and dispose of sediments in an upland area such that they do not encumber other drainage structures and protected areas.
6. Contractor shall be fully responsible to control construction such that sedimentation shall not affect regulatory protected areas, whether such sedimentation is caused by water, wind, or direct deposit.
7. Contractor shall perform construction sequencing such that earth materials are exposed for a minimum of time before they are covered, seeded, or otherwise stabilized to prevent erosion.
8. Areas remaining unstabilized for a period of more than 45 days shall be temporarily seeded and mulched. S traw mulch shall be applied at a minimum rate of 1-1/2 tons/acre.
9. Permanent seeding shall occur between April 1 and June 1, and/or between August 15 and October 15. All seeding from September 15 on shall be straw mulched.
10. Dust shall be controlled through the use of water.
11. Soils to be stockpiled for a period of more than 45 days shall be temporarily seeded and mulched. Contractor shall install silt fencing along downhill side of stockpiles.
12. Contractor shall provide temporary sedimentation basins to control sedimentation and stormwater runoff during the construction period. The contractor shall submit proposed basin locations, designs, etc. to the Engineer for review prior to construction. Temporary sedimentation basins shall meet NHDES requirements.
13. Contractor shall provide necessary erosion control measures to ensure that surface water run-off from unstabilized areas does not carry silt, sediment, and other debris outside of the limits of work.
14. An area shall be considered stable if one of the following has occurred:
  - A. Base course gravels have been installed in areas to be paved;

- B. A minimum of 85% vegetated growth has been established;
  - C. A minimum of 3-inches of non-erosive material, such as stone or riprap, has been installed;
  - D. Erosion control blankets have been properly installed.
15. The smallest practical area shall be disturbed during construction and shall be in conformance with the requirements of Env-Wq 1505.03 for Maximum Open Area Allowed.
  16. All ditches, swales, and drainage basins shall be stabilized prior to directing runoff to them.
  17. All roadways shall be stabilized within 72 hours of achieving finished grade.
  18. All cut and fill slopes shall be loamed and seeded within 72 hours of achieving finished grade.
  19. All permanent and temporary seeding shall be as follows (unless otherwise noted):

<u>Permanent Seeding</u>	<u>Proportion</u>	<u>Germination (min.)</u>	<u>Purity (min.)</u>
<u>Lawns:</u>			
Creeping Red Fescue	50%	85%	95%
Kentucky Bluegrass	40%	85%	90%
Manhattan Perennial Rye	10%	90%	95%

<u>Temporary Seeding*</u>	<u>% Weight</u>	<u>Germination (min.)</u>
Winter Rye	80% min.	85%
Red Fescue (creeping)	4% min.	80%
Perennial Rye Grass	3% min.	90%
Red Clover	3% min.	90%
Other Crop Grass	0.5% max.	
Noxious Weed Seed	0.5% max.	
Inert Matter	1.0% max.	

\* Temporary seed for lawns shall only be planted when permanent grasses cannot be planted due to the growing season.

20. No-mow planting mix (for areas indicated on the plan or as directed) the no-mow planting mix" shall be the "New England Conservation Wildlife Mix" as manufactured by New England Wetland Plants, Inc.
21. Erosion control blankets shall be installed on all disturbed slopes that are steeper than 3-ft horizontal and 1-ft vertical (3:1). erosion control blankets shall be north American Green SC150BN, or approved equivalent.

Winter construction

1. All proposed vegetated areas which do not exhibit a minimum of 85% vegetative growth by October 15th, or which are disturbed after October 15th, shall be stabilized. Stabilization methods shall include seeding and installing erosion control blankets on slopes greater than 3:1 and seeding and placing 3 to 4 tons of mulch per acre, secured with anchored netting, elsewhere. the installation of erosion control blankets or mulch and netting shall not occur over accumulated snow or frozen ground and shall be completed in advance of thaw or spring melt events.
2. All ditches or swales which do not exhibit a minimum of 85% vegetative growth by October 15th, or which are disturbed after October 15th, shall be temporarily stabilized with stone or erosion control blankets appropriate for the design flow conditions.
3. After October 15th, incomplete access road or work area surfaces, where work has stopped for the winter season, shall be protected with a minimum of 3 inches of crushed gravel (NHDOT 304.3).

Rock Blasting:

Best management practices for blasting: All activities related to blasting shall adhere to the following best management practices (bmps) to prevent contamination of groundwater including preparing, reviewing and following an approved blasting plan; proper drilling, explosive handing and loading procedures; observing the entire blasting procedures; evaluating blasting performance; and handling and storage of blasted rock.

1. Loading practices: the following blast hole loading practices to minimize environmental effects shall be followed:
  - A. Drilling logs shall be maintained by the driller and communicated directly to the blaster. The logs shall indicate depths and lengths of voids, cavities, and fault zones or other weak zones encountered as well as groundwater conditions.
  - B. Explosive products shall be managed on-site so that they are either used in the borehole, returned to the delivery vehicle, or placed in secure containers for off-site disposal.
  - C. Spillage around the borehole shall either be placed in the borehole or cleaned up and returned to an appropriate vehicle for handling or placement in secured containers for off-site disposal.
  - D. Loaded explosives shall be detonated as soon as possible and shall not be left in the blastholes overnight, unless weather or other safety concerns reasonably dictate that detonation should be postponed.
  - E. Loading equipment shall be cleaned in an area where wastewater can be properly contained and handled in a manner that prevents release of contaminants to the environment.

- F. Explosives shall be loaded to maintain good continuity in the column load to promote complete detonation. Industry accepted loading practices for priming, stemming, decking and column rise need to be attended to.
2. Explosive selection: The following bmps shall be followed to reduce the potential for groundwater contamination when explosives are used:
- A. Explosive products shall be selected that are appropriate for site conditions and safe blast execution.
- B. Explosive products shall be selected that have the appropriate water resistance for the site conditions present to minimize the potential for hazardous effect of the product upon groundwater.
3. Prevention of misfires: Appropriate practices shall be developed and implemented to prevent misfires.
4. Muck pile management: Muck piles (the blasted pieces of rock) and rock piles shall be managed in a manner to reduce the potential for contamination by implementing the following measures:
- A. Remove the muck pile from the blast area as soon as reasonably possible.
- B. Manage the interaction of blasted rock piles and stormwater to prevent contamination of water supply wells or surface water.
5. Spill prevention measures and spill mitigation: Spill prevention and spill mitigation measures shall be implemented to prevent the release of fuel and other related substances to the environment. the measures shall include at a minimum:
- A. The fuel storage requirements shall include:
1. Storage of regulated substances on an impervious surface.
  2. Secure storage areas against unauthorized entry.
  3. Label regulated containers clearly and visibly.
  4. Inspect storage areas weekly.
  5. Cover regulated containers in outside storage areas.
  6. Wherever possible, keep regulated containers that are stored outside more than 50 feet from surface water and storm drains, 75 feet from private wells, and 400 feet from public wells.
  7. Secondary containment is required for containers containing regulated substances stored outside, except for on premise use heating fuel tanks, or aboveground or underground storage tanks otherwise regulated.
- B. The fuel handling requirements shall include:
1. Except when in use, keep containers containing regulated substances closed and sealed.

2. Place drip pans under spigots, valves, and pumps.
3. Have spill control and containment equipment readily available in all work areas.
4. Use funnels and drip pans when transferring regulated substances.
5. Perform transfers of regulated substances over an impervious surface.

C. The training of on-site employees and the on-site posting of release response information describing what to do in the event of a spill of regulated substances.

D. Fueling and maintenance of excavation, earthmoving and other construction related equipment will comply with the regulations of the New Hampshire Department of Environmental Services (see WD-DWGB-22-6 best management practices for fueling and maintenance of excavation and earthmoving equipment).

Wildlife conservation measures:

- The Project has limited its wetland impacts to those that are unavoidable due to the placement of construction matting for the structure and line replacements.
- Wherever possible, the Project is also avoiding all areas around identified vernal pools by establishing 50-foot buffers around them.
- Areas disturbed during construction will be reseeded and stabilized.
- Erosion controls will be employed around all wetland areas adjacent to proposed work areas. Wildlife-friendly erosion controls, such as those made from woven organic materials or other biodegradable materials, rather than those that use welded plastic netting or polypropylene;
- If appropriate in sensitive areas, exclusion fencing or other physical barrier around the limit of work to prevent migration of animals into the active work zone;
- All observations of threatened or endangered species on the project site shall be reported immediately to the NHF&G nongame and endangered wildlife environmental review program by phone at 603-271-2461 and by email at [NHFGreview@wildlife.nh.gov](mailto:NHFGreview@wildlife.nh.gov), with the email subject line containing the NHB DataCheck tool results letter assigned number, the project name, and the term "Wildlife Species Observation";
- Photographs of the observed species and nearby elements of habitat or areas of land disturbance shall be provided to NHF&G in digital format at the above email address for verification, as feasible;
- In the event a threatened or endangered species is observed on the project site during the term of the permit, the species shall not be disturbed, handled, or harmed in any way prior to consultation with NHF&G and implementation of corrective actions recommended by NHF&G, if any, to assure the project does not appreciably jeopardize the continued existence of threatened and endangered species as defined in Fis 1002.04; and
- The NHF&G, including its employees and authorized agents, shall have access to the property during the term of the permit.

New Hampshire Fish and Game AoT Permit Conditions Related to Threatened and Endangered Species:

- Wood turtles, a state species of special concern, are known within the project area. This species may utilize utility corridors as well as forested areas when near (within 1000 feet) tributaries and rivers. All site operators shall be made aware of their potential presence and be provided a flyer that includes identification and NHFG contact information. Turtles found within the active project area should be relocated immediately to the closest safe location in the direction the turtle was moving – NHFG shall be contacted immediately if this occurs. Although unlikely in this habitat, if a turtle is observed nesting or suspected of nesting, the area shall be marked to avoid impacts, photos shall be taken and provided immediately to NHFG: Melissa Doperalski 603-479-1129 or Josh Megyesy at 978-578-0802. See plan sheets C1.4 - C1.6 for species identification information.
- All manufactured erosion and sediment control products, except for silt fence installed in accordance with Env-Wq 1506.04, utilized for, but not limited to, slope protection, runoff diversion, slope interruption, perimeter control, inlet protection, check dams, and sediment traps shall not contain welded plastic, plastic, or multi-filament or monofilament polypropylene netting or mesh. See Plan sheets C2.0 and C2.3 for specs.
- Turtles may be attracted to disturbed ground during nesting season. Wood turtle nesting season occurs approximately May 15th – July 15th. Nesting areas may include work pads and access roads that are not hard pack gravel and other sandy/gravel work areas. All turtle species nests are protected by NH laws. Be aware of the potential to encounter nesting wildlife in these areas.
- If a turtle nest is observed or suspected, or a turtle is exhibiting nesting behaviors, operators shall contact Melissa Winters (603-479-1129) or Josh Megyesy (978-578-0802) at NHFG immediately for further consultation. Turtle nests or turtles exhibiting nesting behavior shall not be disturbed.
- For structures within 1000ft of the Beebe River and Durgin Brook with work occurring May 15th – July 15th, all material shall be staged/placed within pre-established work pads which have been cleared for and isolated from turtle entry, and all work pads around structures shall be cleared and isolated from turtle entry with wildlife exclusion silt fence prior to work. These areas shall be cleared by a qualified biologist or herpetologist.
- Any failings in silt fence for wildlife exclusion shall be reported to NHFG immediately.
- Matting shall not be placed at Durgin Brook from September 15th to May 15th.
- Sweeps of work areas and access routes shall be conducted immediately prior to start of work and equipment movement in order to minimize the potential of animals entering a work area between the sweep and activity.
- All work activities shall be restricted to the defined roads, construction areas, and staging areas, with no equipment or materials staged or stored outside of the defined areas as shown on plan sheets.
- Minimize work pad areas, including matting, to the greatest extent possible.
- All manufactured erosion and sediment control products, with the exception of turf reinforcement mats, utilized for, but not limited to, slope protection, runoff diversion, slope interruption, perimeter control, inlet protection, check dams, and sediment traps shall not contain plastic, or multifilament or monofilament polypropylene netting or mesh with an opening size of greater than 1/8 inches;
- All observations of threatened or endangered species on the project site shall be reported immediately to the NHFG nongame and endangered wildlife environmental review program by phone at 603-271-2461 and by email at [NHFGreview@wildlife.nh.gov](mailto:NHFGreview@wildlife.nh.gov), with the email subject line containing the NHB DataCheck tool results letter assigned number, the project name, and the term Wildlife Species Observation;
- Photographs of the observed species and nearby elements of habitat or areas of land disturbance shall be provided to NHFG in digital format at the above email address for verification, as feasible;
- In the event a threatened or endangered species is observed on the project site during the term of the permit, the species shall not be disturbed, handled, or harmed in any way prior to consultation with NHFG and implementation of corrective actions recommended by NHFG.
- Site operators shall be allowed to relocate wildlife encountered if discovered within the active work zone and if in direct harm from project activities. Wildlife shall be relocated in close proximity to the capture location but outside of the work zone and in the direction the individual was heading. NHFG shall be contacted immediately if this action occurs.

# Wood Turtle

*(Glyptemys insculpta)*

(New Hampshire Species of Special Concern)



- Neck and forelimbs are orange.
- Characterized by its highly sculpted shell with each large scute taking on an irregular pyramidal shape.
- Adults can be 5-8 inches long.



**Please report sightings to NH Fish and Game at [RAARP@wildlife.nh.gov](mailto:RAARP@wildlife.nh.gov) or at 603-271-2461. Photo documentation, location, and date/time of observation is helpful.**

**NOTE: It is illegal to remove a wood turtle from the wild (RSA 207:1, FIS 804.02).**



# Management Guidelines for Wood Turtles

*(Glyptemys insculpta)*

Nesting Areas  
Agricultural Land  
Forest Land  
Roads

## Managing Forests

Forest management activities have the potential to both kill Wood Turtles and degrade habitat. However, if applied carefully, timber harvesting can be compatible with Wood Turtle habitat conservation and enhancement.

### Guidelines for managing forests:

1. Restrict all logging operations within 300 ft of Wood Turtle streams during the active period: April–October.
2. Minimize harvests within 300 ft of all Wood Turtle streams and within 1000 ft of *regionally significant*\* streams.
3. *If early-successional habitats are completely absent*: small group selection cuts (top image) created during the inactive period may enhance habitat.
4. Discontinue logging road use after harvests are complete.

\* Regionally significant streams are streams identified as critical to Wood Turtle conservation in the Northeast. Contact your state wildlife agency if you are uncertain about the status of a stream.

## Wood Turtle Habitat

Wood Turtles live in and around cool, clean, slow-moving streams and rivers from Virginia to southern Canada. These semiaquatic turtles overwinter and mate in streams, but spend much of the warmer months roaming the surrounding landscape. They utilize a wide range of upland habitats from fields and shrublands to mature forest.

## Found a Wood Turtle?

If you find a Wood Turtle, please take pictures, note the location, and alert your state agency to your discovery. It is always best to leave turtles where you find them unless they are directly in harm's way (such as on a road), in which case the traveling turtle should be moved and released in the direction that it was headed.

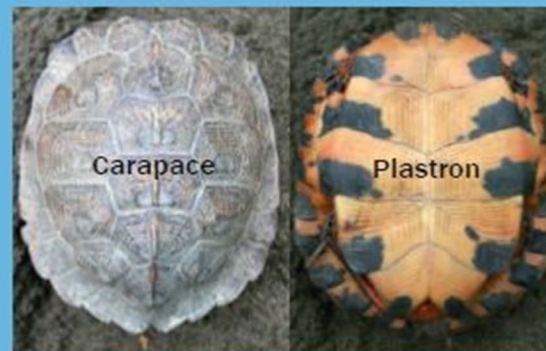

## Active Period



[www.americanturtles.org](http://www.americanturtles.org)

[www.parcplace.org](http://www.parcplace.org)



Supported by: U.S. Fish and Wildlife Service Competitive State Wildlife Grants



## Creating Nesting Areas

Wood Turtles require open, well-drained, elevated, and exposed areas of sand and/or gravel for nesting. These conditions occur naturally in the form of sand/gravel bars, beaches, and cutbanks. Wood Turtles also make use of anthropogenic features for nesting such as gravel pits, boat ramps, powerline corridors, and roadsides.

### Considerations for managing nesting habitat:

1. Survey and map natural streamside nesting areas using ground surveys and aerial photographs.
2. Manage natural streamside nesting habitat by clearing vegetation during the inactive season.
3. If natural streamside nesting features are not available, evaluate existing anthropogenic nesting habitat and protect, manage, and/or augment as necessary. Create nesting habitat during winter.

### Creating nesting habitat:

Clear land to expose mixed poorly-graded sand and gravel, or build mound(s) of sand in open areas near streams ( $\leq 200$  ft). Avoid placing nesting areas near roads and, if possible, disperse nesting areas to decrease the chance of depredation. Suggested dimensions for nesting mounds: 60 x 25 x 5 ft.



## Managing Agricultural Land

Agricultural land can be attractive and beneficial for Wood Turtles if properly managed. Unfortunately, agricultural machinery can also kill Wood Turtles and harm local populations.



### Guidelines for managing agricultural land:

1. Establish unfragmented and unmanaged riparian/upland buffers of  $\geq 300$  ft around all Wood Turtle streams and buffers of  $\geq 1000$  ft around *regionally significant*\* streams.
2. Manage fields during the inactive period (Nov 1–Mar 31). If warm season management is necessary, leave unmanaged buffers  $>35$  ft at the streamside edge of fields and maintain them during winter.
3. Use crop varieties that can be harvested in October.
4. Implement grazing or off-season burning. Exclude livestock from the riparian corridor.
5. Use sickle bar mowers and raise blade height  $>6$  inches when possible.
6. Conduct systematic surveys to identify heavily used turtle areas (e.g., early summer nesting congregations in fields).



\*See Managing Forests

## Minimizing Road Mortalities



Road mortalities are one of the major factors contributing to the decline of Wood Turtles. Roads that run parallel to Wood Turtle streams, especially within 300 ft, are particularly harmful for nearby populations. The most effective way to protect Wood Turtles is to restrict the construction of new roads near important habitat.

### Guidelines for minimizing road mortalities:

1. Prohibit road construction within 300 ft of all Wood Turtle streams and where feasible within 1000 ft of *regionally significant*\* streams.
2. Culverts and crossings should be avoided whenever possible near Wood Turtle streams.
3. If a road crossing is necessary, it is critical that:
  - A. The culvert or bridge allows turtles to pass below (e.g., is not perched or undersized\*\*).
  - B. The road surfaces and side slopes are not attractive to Wood Turtles (e.g., avoid creating nesting or early-successional habitat).
4. Minimize road construction up to 3.5 miles from *regionally significant*\* streams.

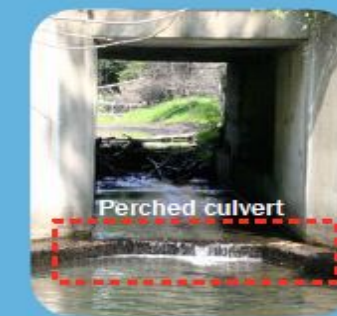

\*See Managing Forests \*\*See Stream Crossing Standards



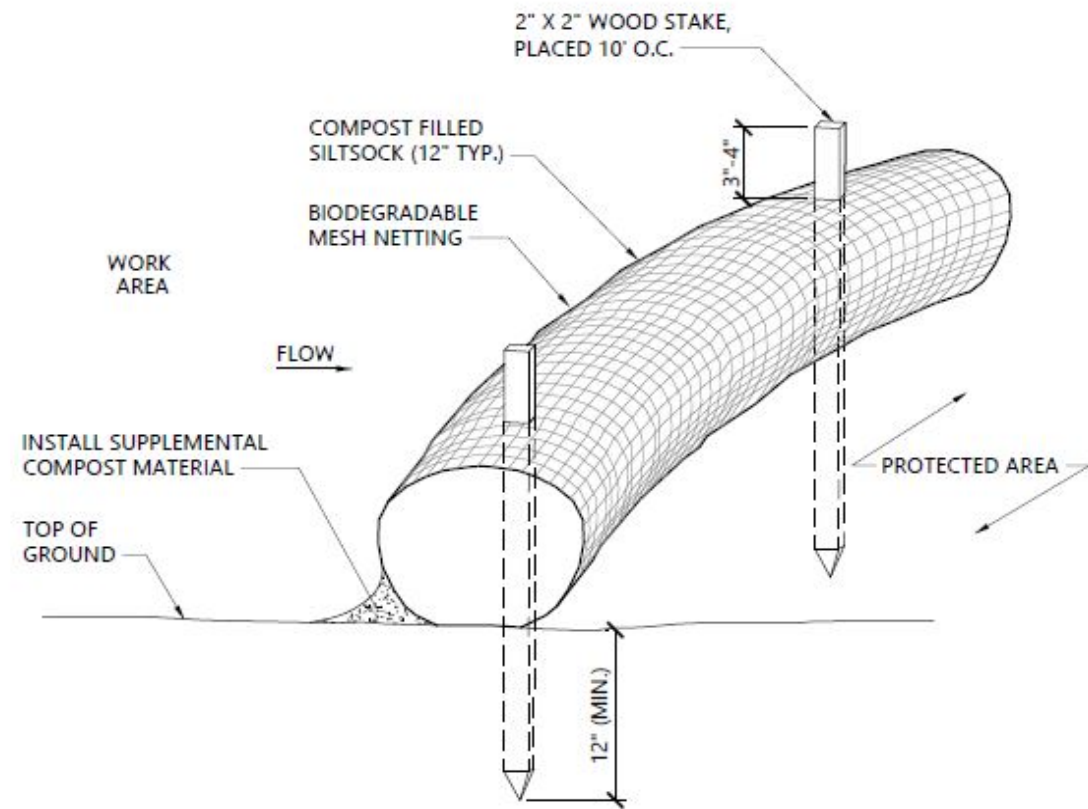

**NOTES**

1. SILT SOCK SHALL BE FILTREXX SILT SOCK WITH SILT SOCK NATURAL ORIGINAL OR NATURAL PLUS+ COMPOST FILL.
2. SILT SOCKS SHALL OVERLAP A MINIMUM OF 12 INCHES.
3. SILT SOCK SHALL BE INSPECTED PERIODICALLY AND AFTER ALL STORM EVENTS, AND REPAIR OR REPLACEMENT SHALL BE PERFORMED PROMPTLY AS NEEDED.
4. COMPOST MATERIAL SHALL BE DISPERSED ON SITE, AS DETERMINED BY THE ENGINEER.

**Siltsock - Erosion Control Barrier**

N.T.S.

Source: VHB

REV

1/16

LD\_658

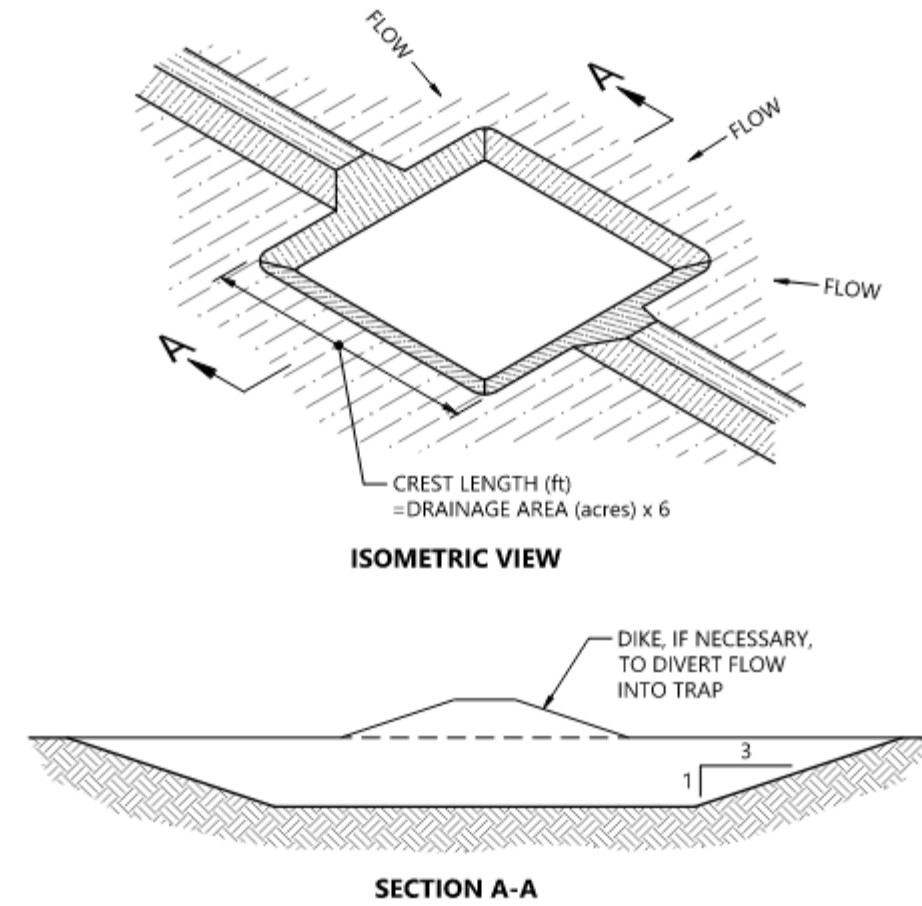

**NOTES**

1. THE TRAP SHALL BE INSTALLED AS CLOSE TO THE DISTURBED AREA OR SOURCE OF SEDIMENT AS POSSIBLE .
2. THE MAXIMUM CONTRIBUTING DRAINAGE AREA TO THE TRAP SHALL BE LESS THAN 5 ACRES.
3. THE MINIMUM VOLUME OF THE TRAP SHALL BE 3,600 CUBIC FEET OF STORAGE FOR EACH ACRE OF DRAINAGE AREA.
4. THE SIDE SLOPES OF THE TRAP SHALL BE 3:1 OR FLATTER, AND SHALL BE STABILIZED IMMEDIATELY AFTER THEIR CONSTRUCTION.
5. THE OUTLET OF THE TRAP SHALL BE A MINIMUM OF ONE FOOT BELOW THE CREST OF THE TRAP AND SHALL DISCHARGE TO A STABILIZED AREA.
6. THE TRAP SHALL BE CLEANED WHEN 50 PERCENT OF THE ORIGINAL VOLUME IS FILLED.
7. THE MATERIALS REMOVED FROM THE TRAP SHALL BE PROPERLY DISPOSED OF AND STABILIZED.

**Temporary Sediment Trap**

N.T.S.

Source: NH Stormwater Manual

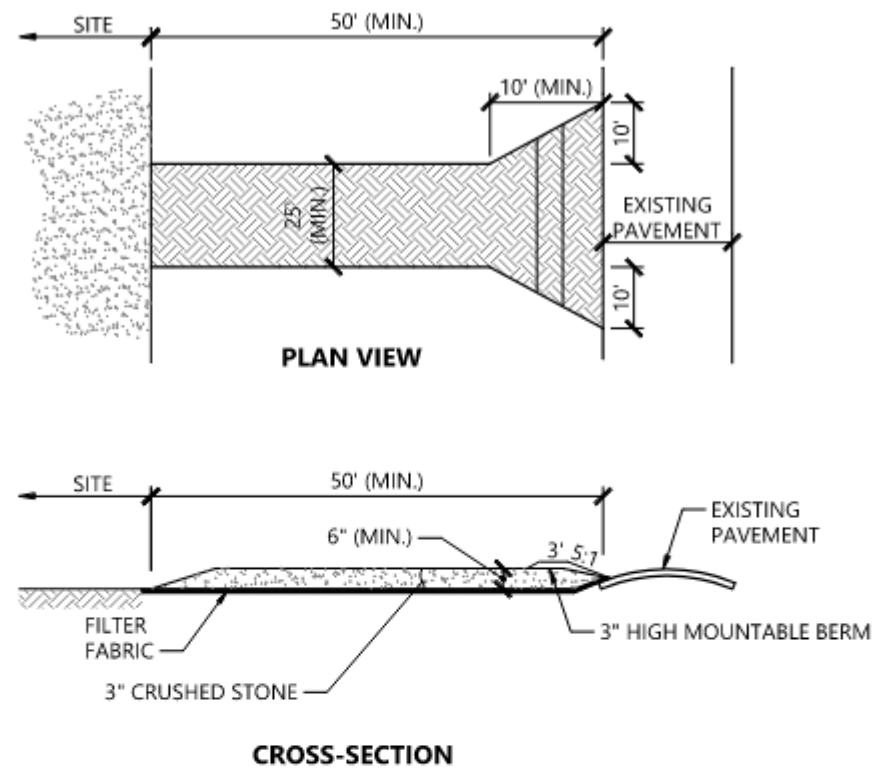

**NOTES**

1. EXIT WIDTH SHALL BE A TWENTY-FIVE (25) FOOT MINIMUM, BUT NOT LESS THAN THE FULL WIDTH AT POINTS WHERE INGRESS OR EGRESS OCCURS.
2. THE EXIT SHALL BE MAINTAINED IN A CONDITION WHICH SHALL PREVENT TRACKING OR FLOWING OF SEDIMENT ONTO PUBLIC RIGHTS-OF-WAY. THIS MAY REQUIRE PERIODIC TOP DRESSING WITH ADDITIONAL STONE AS CONDITIONS DEMAND AND REPAIR OR CLEANOUT OF ANY MEASURES USED TO TRAP SEDIMENT. ALL SEDIMENT SPILLED, DROPPED, WASHED OR TRACKED ONTO PUBLIC RIGHTS-OF-WAY MUST BE REMOVED IMMEDIATELY. BERM SHALL BE PERMITTED. PERIODIC INSPECTION AND MAINTENANCE SHALL BE PROVIDED AS NEEDED.
3. STABILIZED CONSTRUCTION EXIT SHALL BE REMOVED PRIOR TO FINAL FINISH MATERIALS BEING INSTALLED.

**Stabilized Construction Exit**

N.T.S.

Source: VHB

5/17

LD 682-NH

RECOMMENDED MINIMUM SPACING FOR WATERBARS

GRADE	A
≥ 10%	80'
≥ 15%	60'
> 20%	45'

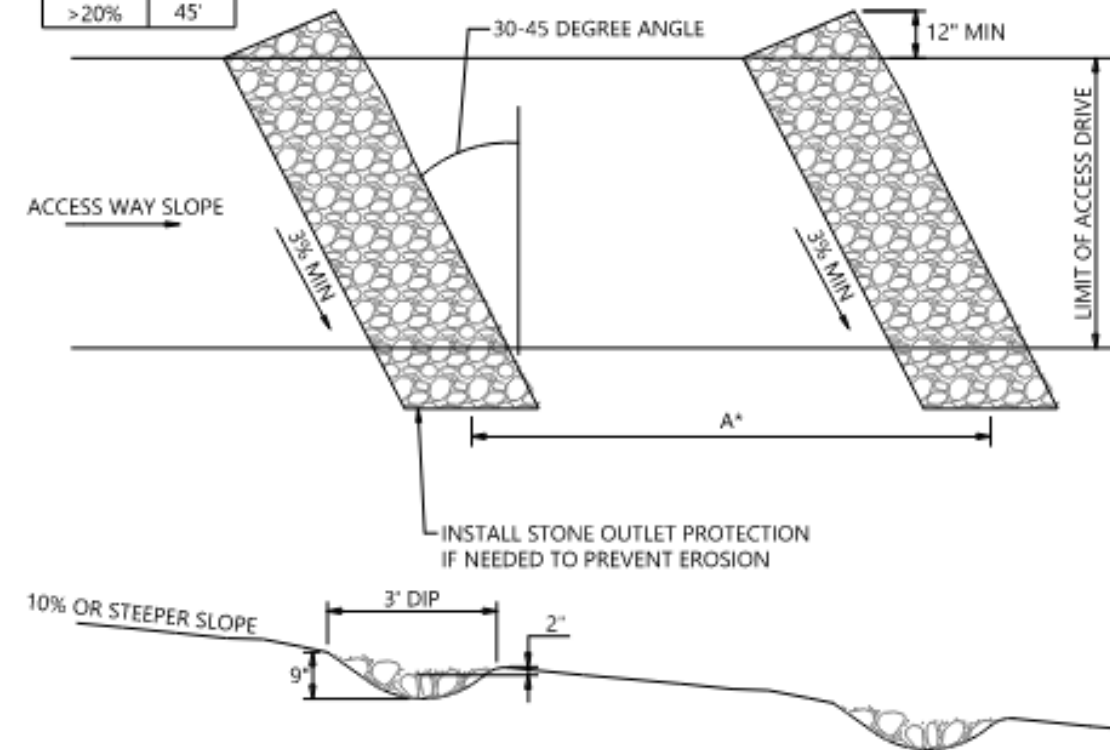

**NOTES**

1. WATERBARS SHOULD BE INSTALLED IN SECTIONS WITH SLOPES GREATER THAN OR EQUAL TO 10%.
2. CONTRACTOR TO OBSERVE THE CLEARINGS DURING A RAINSTORM TO DETERMINE IF ADDITIONAL WATERBARS OR ADJUSTMENTS TO WATERBARS ARE NEEDED.
3. WATERBAR DESIGN AND SPACING PROVIDED FOR GUIDANCE TO CONTROL EROSION ALONG CROSS-COUNTRY CLEARINGS. THE CONTRACTOR SHALL DETERMINE IF OTHER APPROPRIATE MEASURES ARE REQUIRED TO CONTROL RUNOFF AND EROSION IN CLEARING AREAS.
4. FOR WIDER LIMITS OF CLEARING MULTIPLE LOG LENGTHS MAY BE REQUIRED.

**Waterbars (Alternative) - For Utility Access Areas**

N.T.S.

Source: VHB

11/15

LD\_

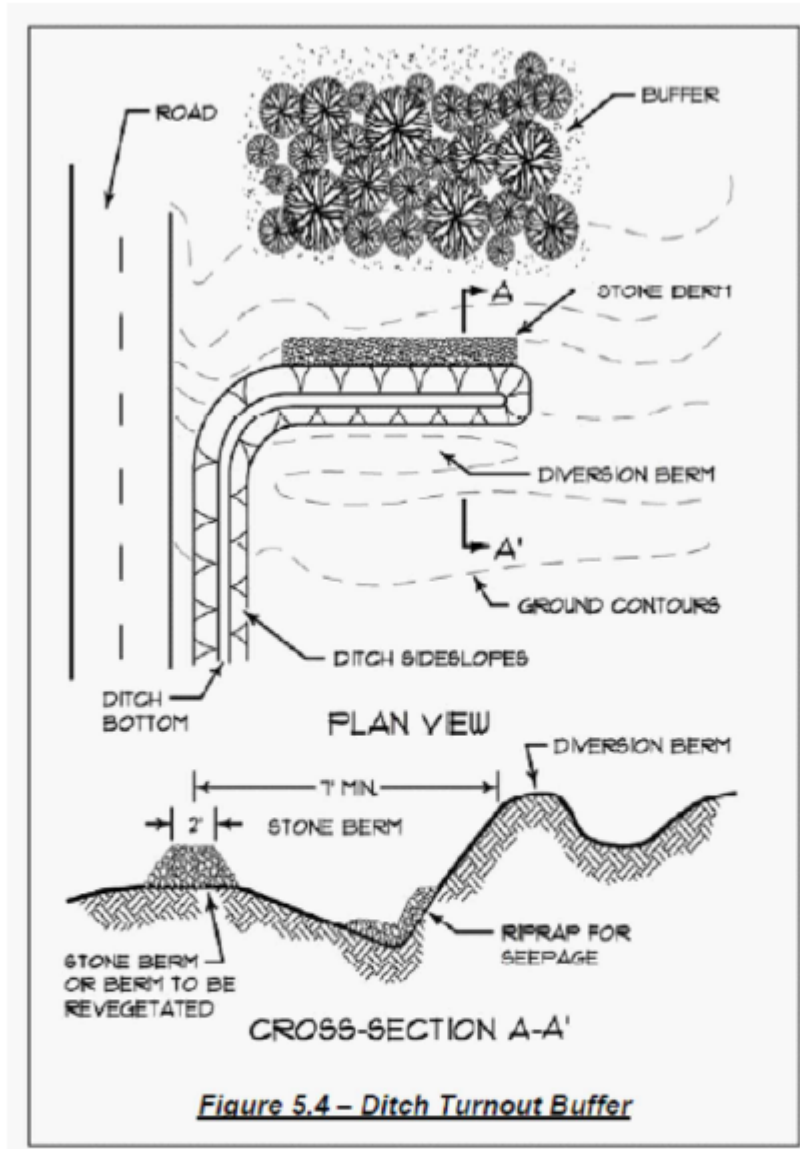
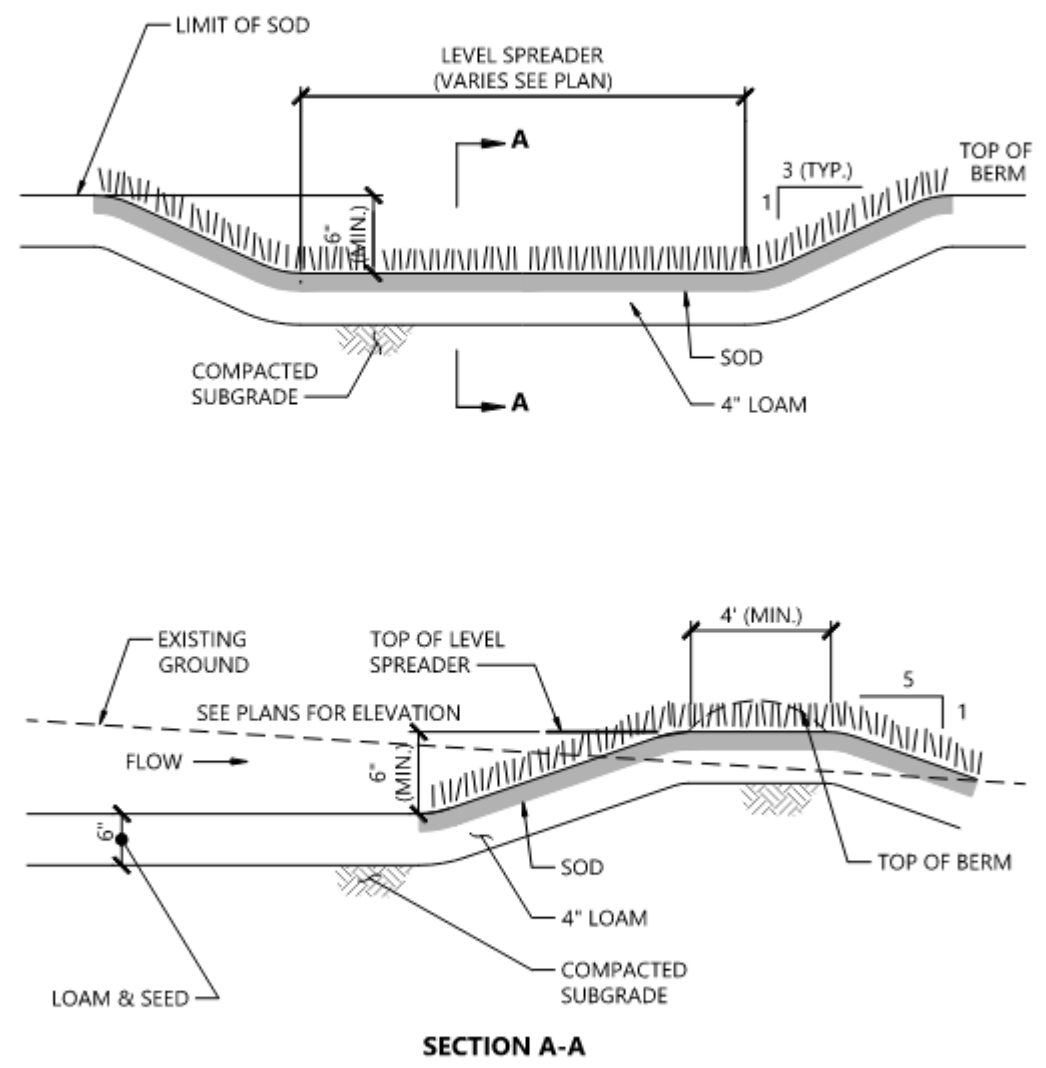

**Figure 5.4 – Ditch Turnout Buffer**

- **Stone Berm Specifications:** The stone berm to which the ditch turn-out delivers the runoff must be at least 20 feet in length and must be constructed along the contour. It must be at least one-foot high and two feet across the top with 2:1 side slopes.
- **Stone Size:** The stone must be coarse enough that it will not clog with sediment. Stone for stone bermed level lip spreaders must consist of sound durable rock that will not disintegrate by exposure to water or weather. Fieldstone, rough quarried stone, blasted ledge rock or tailings may be used. The rock must be well graded with a median size of approximately 3 inches and a maximum size of 6 inches. See Table 5.4 above.

**Ditch Turnout**

N.T.S. Source: MDEP



**Level Spreader Detail**

N.T.S. Source: VHB

1/16 LD 172

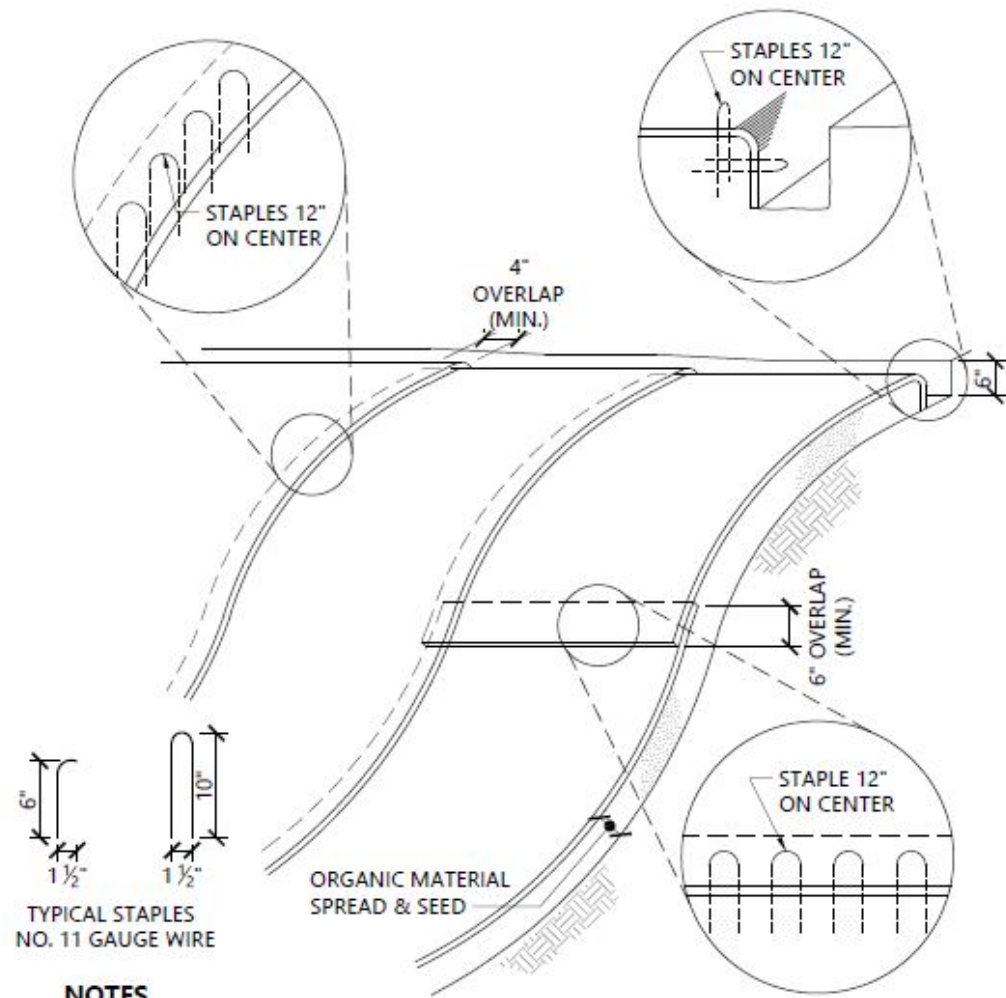

**NOTES**

1. BEGIN AT THE TOP OF BLANKET INSTALLATION AREA BY ANCHORING BLANKET IN A 6" DEEP TRENCH BACKFILL AND COMPACT TRENCH AFTER STAPLING.
2. ROLL THE BLANKET DOWN THE SWALE IN THE DIRECTION OF THE WATER FLOW.
3. THE EDGES OF BLANKETS MUST BE STAPLED WITH APPROX. 4 INCH OVERLAP WHERE 2 OR MORE STRIP WIDTHS ARE REQUIRED.
4. WHEN BLANKETS MUST BE SPLICED DOWN THE SWALE, PLACE UPPER BLANKET END OVER LOWER END WITH 6 INCH (MIN.) OVERLAP AND STAPLE BOTH TOGETHER.
5. METHOD OF INSTALLATION SHALL BE AS PER MANUFACTURER'S RECOMMENDATIONS.
6. EROSION CONTROL BLANKETS SHALL BE USED IN ALL AREAS WHERE SLOPES EXCEED 3:1.
7. EROSION CONTROL BLANKETS SHALL NOT CONTAIN WELDED PLASTIC, PLASTIC MULTI-FILAMENT OR MONO-FILAMENT POLYPROPYLENE NETTING OR MESH.

**Erosion Control Blanket Slope Installation**

N.T.S. Source: VHB REV 1/16 LD\_680

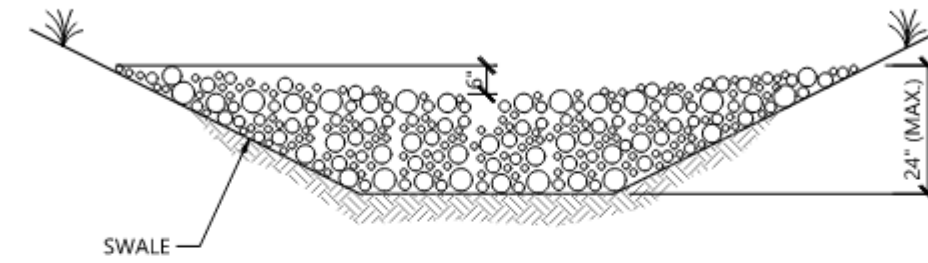

**ELEVATION**

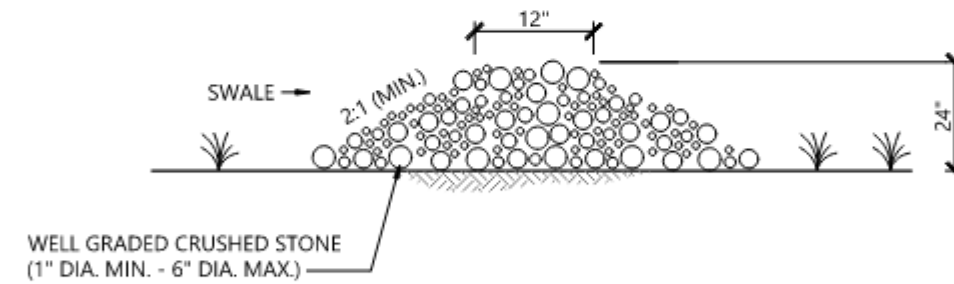

**CROSS-SECTION**

**NOTES**

1. TOP OF DOWNGRADIENT CHECKDAM AND BOTTOM OF UPGRADE CHECKDAM TO BE SET AT THE SAME ELEVATION.
2. STONE CHECKDAMS MAY BE REMOVED WHEN 90% OF THE VEGETATIVE COVER IS ESTABLISHED.

**Temporary Stone Checkdam**

N.T.S. Source: VHB REV

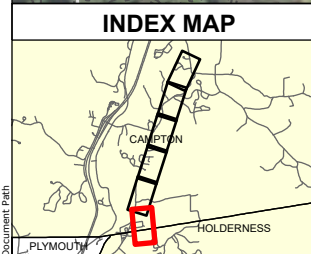
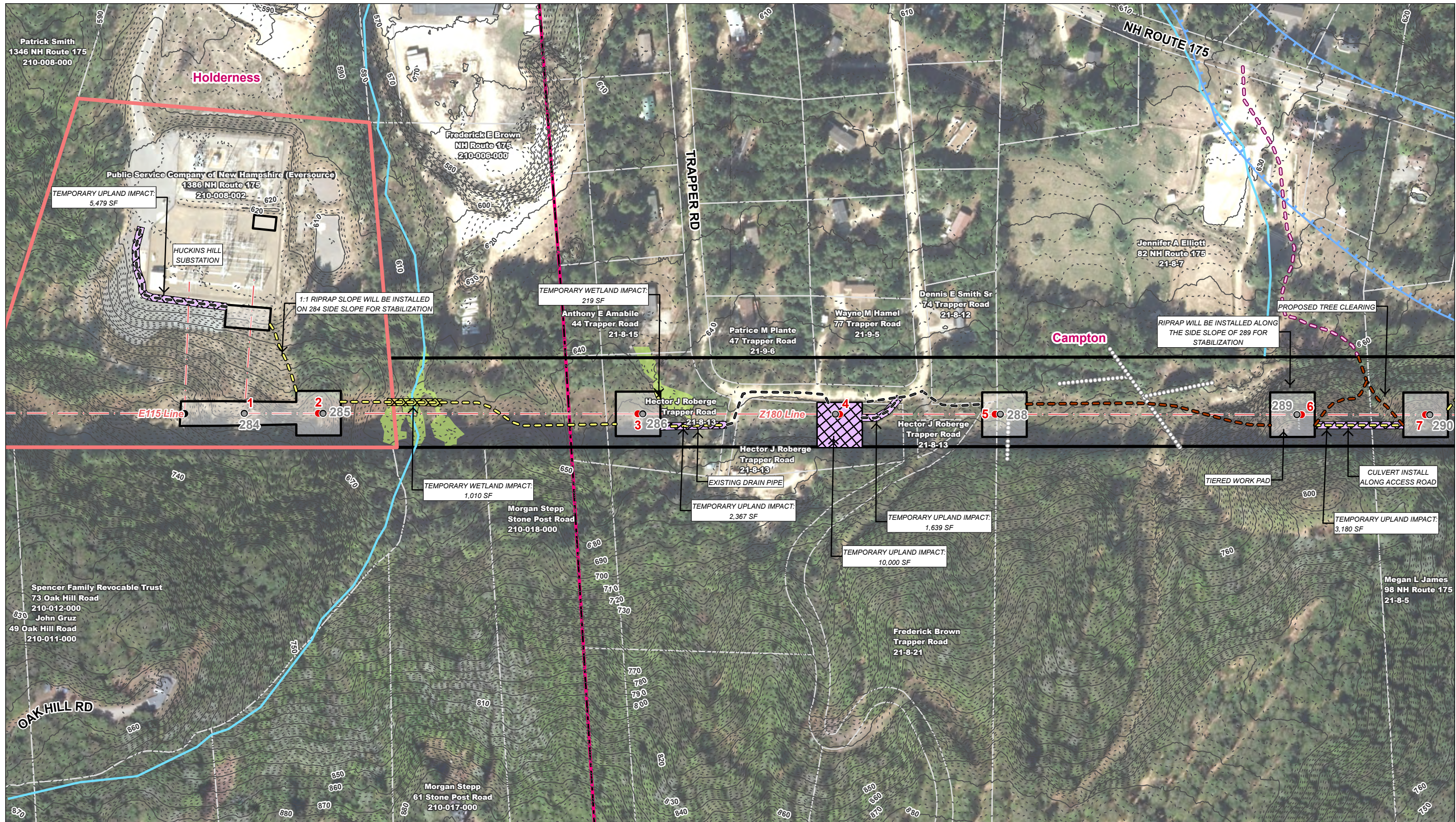

● Existing Structure	— Off-ROW Access Pending Rights	▨ Temporary Construction Matting	○ Stonewall
● Existing Structure to be Removed	— Alternative Off-ROW Access	▨ Upland Construction Matting	- - - 2' Contour Line
● Proposed Structure	— Access Road to be Improved	▨ WorkPad	— 10' Contour Line
— Overhead Eversource Line	— Delineated Intermittent Watercourse	▨ FEMA 100-Year Flood Zone	▨ Eversource Owned Parcel
— Existing Right-of-Way (ROW)	— Delineated Perennial Watercourse	▨ NH Priority Resource Area Flood Plain Wetlands Adjacent to Tier 3 Streams	▨ Parcel Boundary
— Existing Access	— Watercourse (not delineated)		▨ Municipal Boundary
— Proposed Access	— Field Delineated Wetland		
— Alternative Access			

NO.	DATE	REVISIONS

**EVERSOURCE ENERGY**

**Z180 Line Structure Replacement Projects**

Holderness and Campton, NH      MAP SHEET 1 of 6

Date: January, 2023

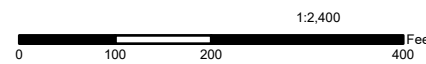

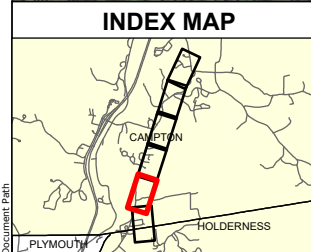
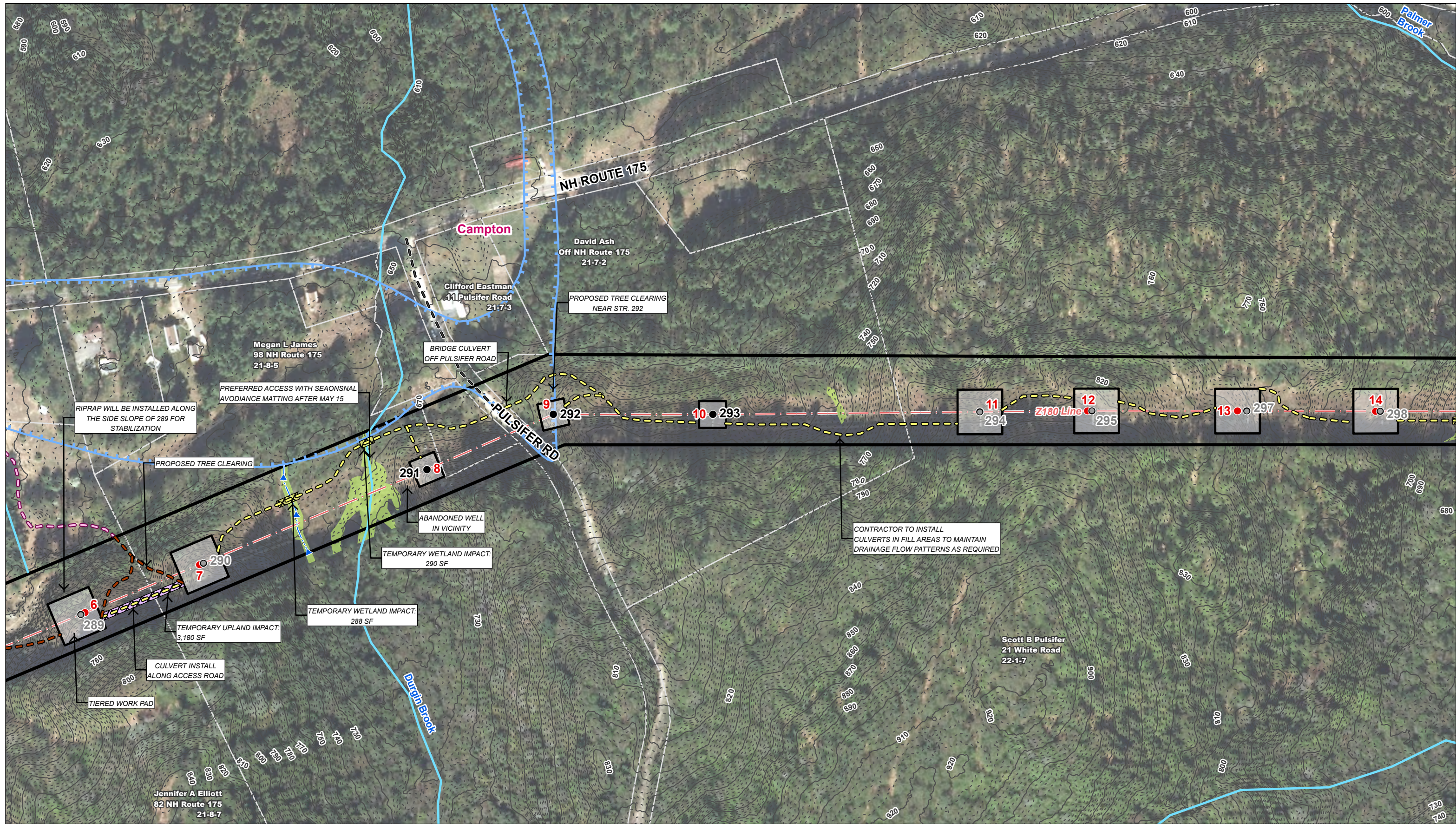

- Existing Structure
- Existing Structure to be Removed
- Proposed Structure
- Overhead Eversource Line
- Existing Right-of-Way (ROW)
- Existing Access
- Proposed Access
- Alternative Access
- Off-ROW Access Pending Rights
- Alternative Off-ROW Access
- Access Road to be Improved
- Delineated Intermittent Watercourse
- Delineated Perennial Watercourse
- Watercourse (not delineated)
- Field Delineated Wetland
- Temporary Construction Matting
- Upland Construction Matting
- WorkPad
- FEMA 100-Year Flood Zone
- NH Priority Resource Area Flood Plain Wetlands Adjacent to Tier 3 Streams
- Stonewall
- 2' Contour Line
- 10' Contour Line
- Eversource Owned Parcel
- Parcel Boundary
- Municipal Boundary

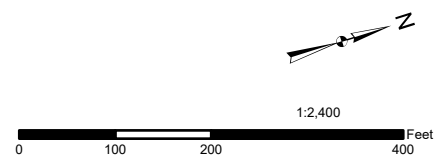

NO.	DATE	REVISIONS

**EVERSOURCE ENERGY**

**Z180 Line Structure Replacement Projects**

Campton, NH

Date: January, 2023

MAP SHEET 2 of 6

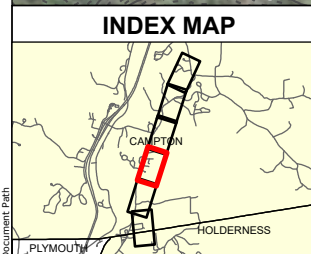

- Existing Structure
- Existing Structure to be Removed
- Proposed Structure
- Overhead Eversource Line
- Existing Right-of-Way (ROW)
- Existing Access
- Proposed Access
- Alternative Access
- Off-ROW Access Pending Rights
- Alternative Off-ROW Access
- Access Road to be Improved
- Delineated Intermittent Watercourse
- Delineated Perennial Watercourse
- Watercourse (not delineated)
- Field Delineated Wetland
- Temporary Construction Matting
- Upland Construction Matting
- WorkPad
- FEMA 100-Year Flood Zone
- NH Priority Resource Area Flood Plain Wetlands Adjacent to Tier 3 Streams
- Stonewall
- 2' Contour Line
- 10' Contour Line
- Eversource Owned Parcel
- Parcel Boundary
- Municipal Boundary

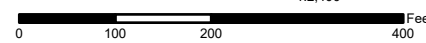

NO.	DATE	REVISIONS

**EVERSOURCE ENERGY**

**Z180 Line Structure Replacement Projects**

Campton, NH

Date: January, 2023

MAP SHEET 3 of 6

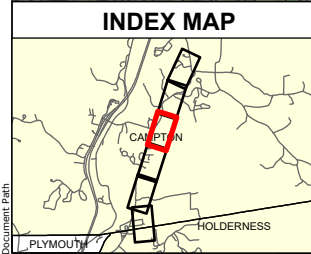
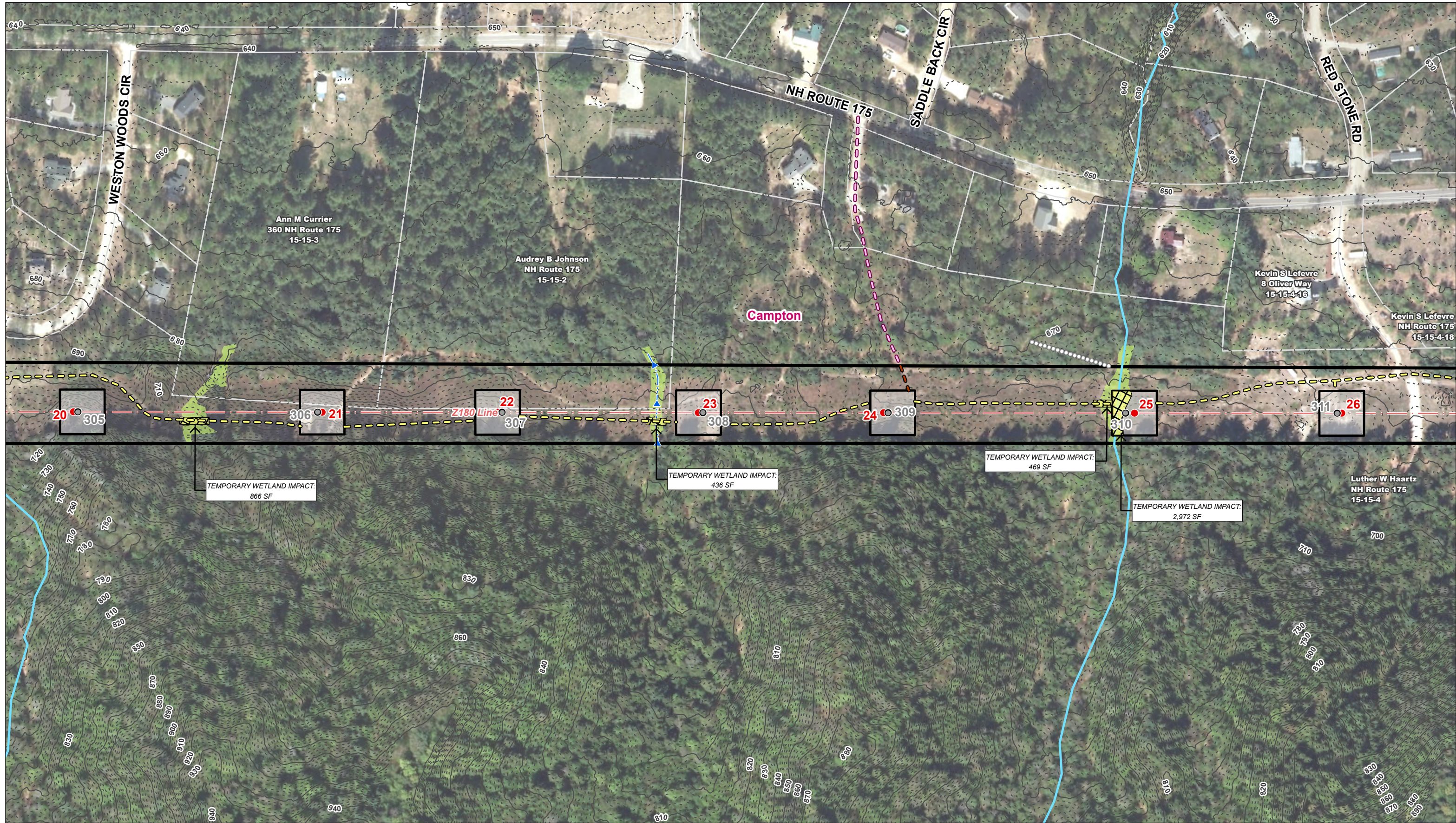

<ul style="list-style-type: none"> <li>● Existing Structure</li> <li>● Existing Structure to be Removed</li> <li>● Proposed Structure</li> <li>— Overhead Eversource Line</li> <li>— Existing Right-of-Way (ROW)</li> <li>— Existing Access</li> <li>— Proposed Access</li> <li>— Alternative Access</li> </ul>	<ul style="list-style-type: none"> <li>— Off-ROW Access Pending Rights</li> <li>— Alternative Off-ROW Access</li> <li>— Access Road to be Improved</li> <li>— Delineated Intermittent Watercourse</li> <li>— Delineated Perennial Watercourse</li> <li>— Watercourse (not delineated)</li> <li>— Field Delineated Wetland</li> </ul>	<ul style="list-style-type: none"> <li>Temporary Construction Matting</li> <li>Upland Construction Matting</li> <li>WorkPad</li> <li>FEMA 100-Year Flood Zone</li> <li>NH Priority Resource Area Flood Plain Wetlands Adjacent to Tier 3 Streams</li> </ul>	<ul style="list-style-type: none"> <li>○ Stonewall</li> <li>- - - 2' Contour Line</li> <li>— 10' Contour Line</li> <li>Eversource Owned Parcel</li> <li>Parcel Boundary</li> <li>Municipal Boundary</li> </ul>
---	--	---	--

NO.	DATE	REVISIONS

**EVERSOURCE ENERGY**

**Z180 Line Structure Replacement Projects**

Campton, NH

Date: January, 2023

MAP SHEET 4 of 6

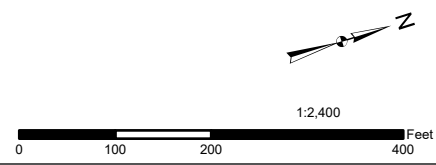



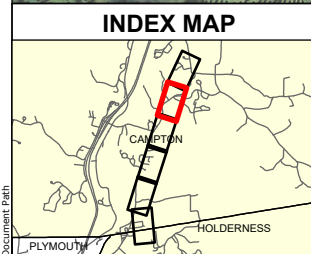
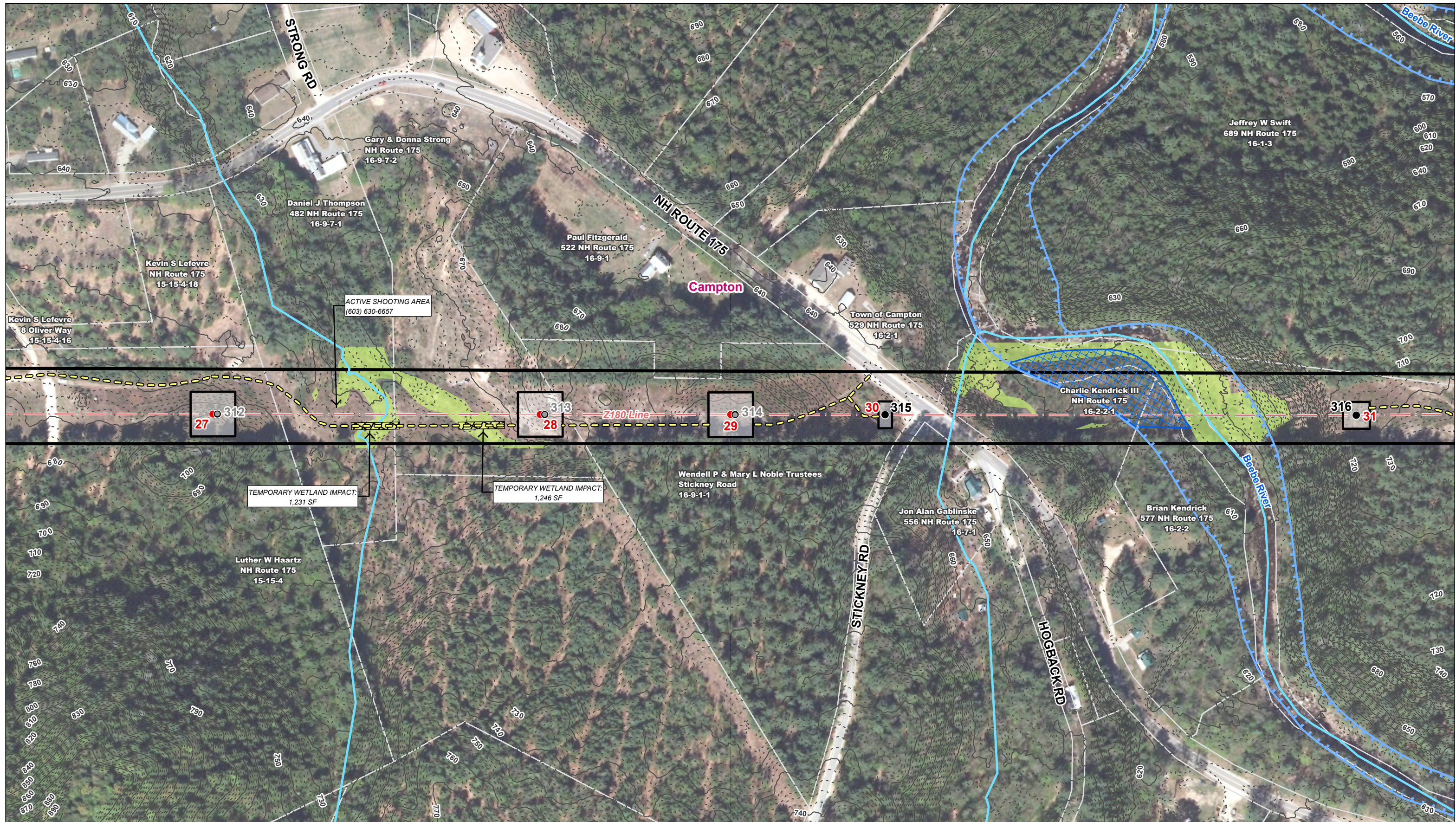

● Existing Structure	— Off-ROW Access Pending Rights	Temporary Construction Matting	○ Stonewall
● Existing Structure to be Removed	— Alternative Off-ROW Access	Upland Construction Matting	- - - 2' Contour Line
● Proposed Structure	— Access Road to be Improved	WorkPad	— 10' Contour Line
— Overhead Eversource Line	— Delineated Intermittent Watercourse	FEMA 100-Year Flood Zone	— Eversource Owned Parcel
— Existing Right-of-Way (ROW)	— Delineated Perennial Watercourse	NH Priority Resource Area Flood Plain Wetlands Adjacent to Tier 3 Streams	— Parcel Boundary
— Existing Access	— Watercourse (not delineated)		— Municipal Boundary
— Proposed Access	— Field Delineated Wetland		
— Alternative Access			

NO.	DATE	REVISIONS

**EVERSOURCE ENERGY**

**Z180 Line Structure Replacement Projects**

Campton, NH

Date: January, 2023

MAP SHEET 5 of 6

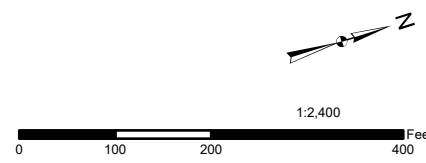

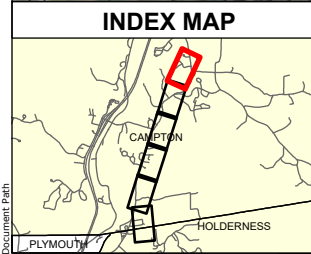

- Existing Structure
- Existing Structure to be Removed
- Proposed Structure
- Overhead Eversource Line
- Existing Right-of-Way (ROW)
- Existing Access
- Proposed Access
- Alternative Access
- Off-ROW Access Pending Rights
- Alternative Off-ROW Access
- Access Road to be Improved
- Delineated Intermittent Watercourse
- Delineated Perennial Watercourse
- Watercourse (not delineated)
- Field Delineated Wetland
- Temporary Construction Matting
- Upland Construction Matting
- WorkPad
- FEMA 100-Year Flood Zone
- NH Priority Resource Area Flood Plain Wetlands Adjacent to Tier 3 Streams
- Stonewall
- 2' Contour Line
- 10' Contour Line
- Eversource Owned Parcel
- Parcel Boundary
- Municipal Boundary

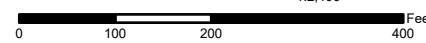

NO.	DATE	REVISIONS

**EVERSOURCE ENERGY**

**Z180 Line Structure Replacement Projects**

Campton, NH

Date: January, 2023

MAP SHEET 6 of 6